

# SYNDICAT MIXTE POUR LE DEVELOPPEMENT ECONOMIQUE DU NERACAIS

## Ruisseau de Malé Ruisseau de Caillou



### Croquis de repérage

Date d'élaboration: Janvier 2016

(Sans Echelle)

Réf dossier : 2016/0102

Date d'édition: 22/02/2016

Modifié le :

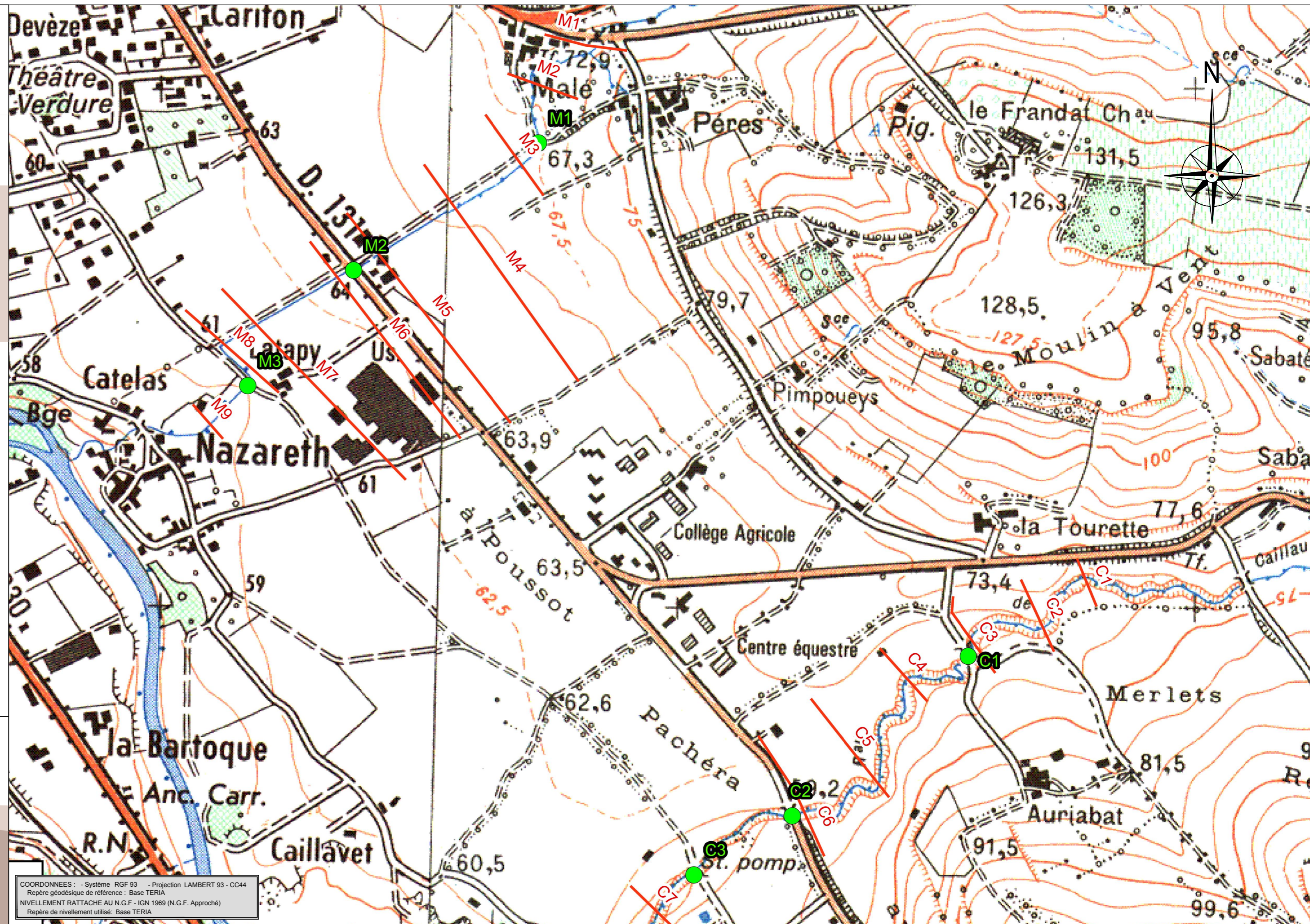



# SYNDICAT MIXTE POUR LE DEVELOPPEMENT ECONOMIQUE DU NERACAIS

## Ruisseau de Malé



# RELEVÉ ALTIMÉTRIQUES Profils M1 à M9

Date d'élaboration: Janvier 2016

Echelle 1/2000

Réf dossier : 2016/0102

Date d'édition: 22/02/2016

Modifié le :

  
**PANGÉO** CONSEIL  
L'énergie de la juste mesure  
www.pangeo-conseil.fr

**Joseph PASCUAL**  
Géomètre-Expert Foncier DPLG  
24, Bld Edouard Lacour - 47031 AGEN CEDEX  
Tél : 05 53 66 31 52 - Fax : 05 53 68 30 26  
Adresse mail : agen@pangeo-conseil.fr

SARL DE GÉOMÈTRES-EXPERTS

C:\Users\jean-philippe\appdata\local\temp\AcPublish\_7488\Agrinove-2016-01-TOP(3).dwg

COORDONNÉES : - Système RGF 93 - Projection LAMBERT 93 - CC44  
Réfère géodésique de référence: Base TERIA  
NIVELLEMENT RATTACHE AU N.G.F. - IGN 1969 (N.G.F. Approché)  
Repère de nivellement utilisé: Base TERIA

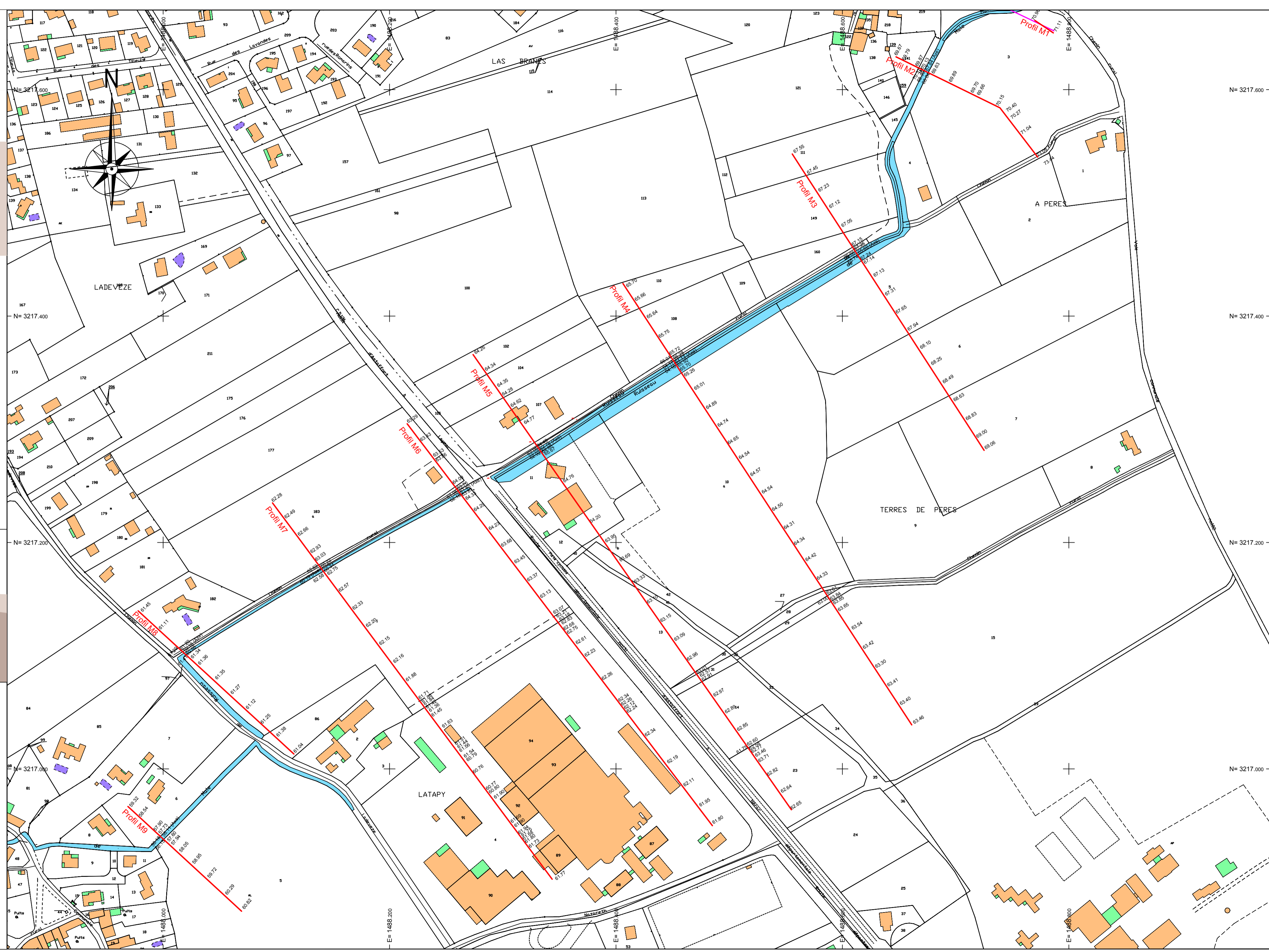

Profil n°: M2

Echelle en X : 1/500

Echelle en Y : 1/200

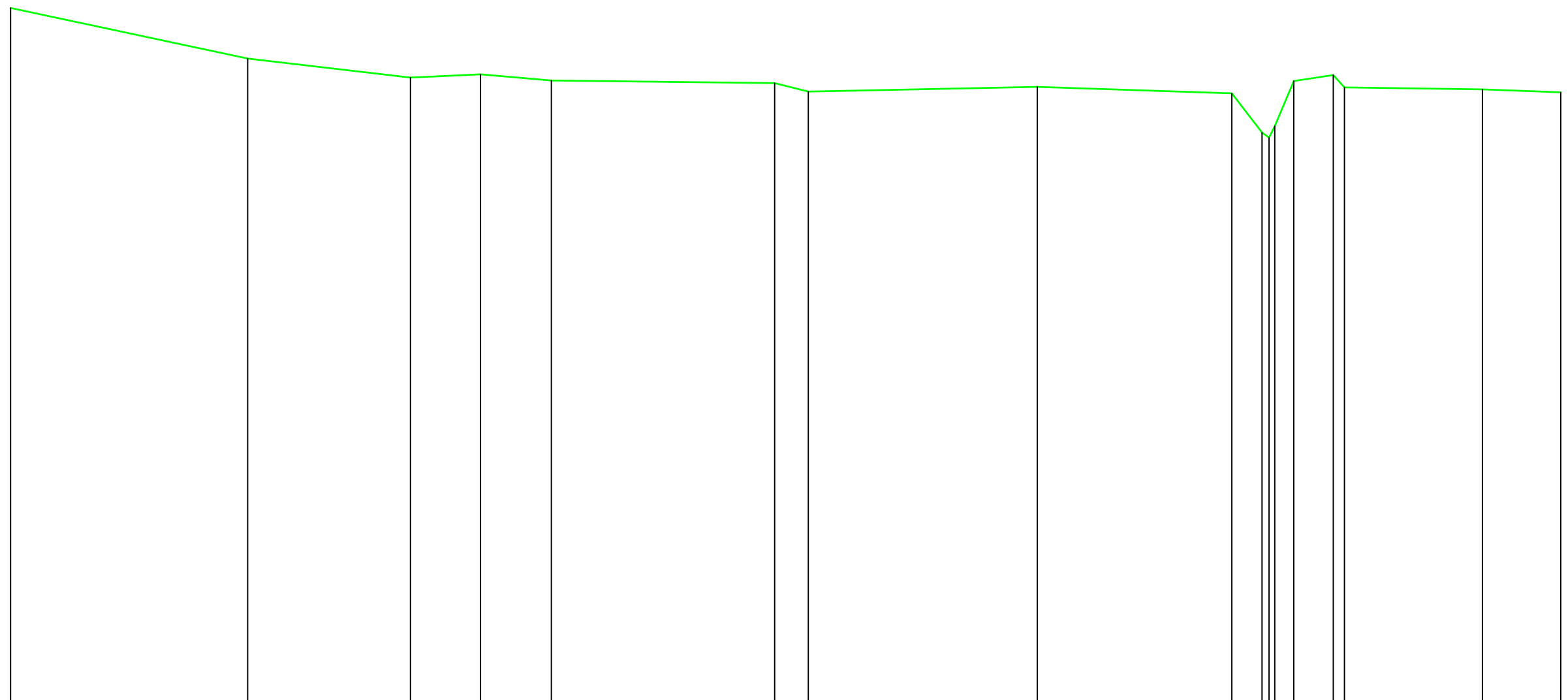

PC : 45.00 m

|                         |       |       |       |       |       |       |       |        |        |        |        |        |        |        |        |        |
|-------------------------|-------|-------|-------|-------|-------|-------|-------|--------|--------|--------|--------|--------|--------|--------|--------|--------|
| Numéros des points TN   | 1     | 2     | 3     | 4     | 5     | 6     | 7     | 8      | 9      | 10     | 12     | 13     | 14     | 15     | 16     | 17     |
| Altitudes TN            | 73.09 | 71.04 | 70.27 | 70.40 | 70.15 | 70.04 | 69.70 | 69.89  | 69.63  | 68.04  | 68.30  | 70.13  | 70.37  | 69.67  | 69.79  | 69.67  |
| Distances cumulées TN   | 0.00  | 24.02 | 40.52 | 47.61 | 54.79 | 77.42 | 80.83 | 104.02 | 123.74 | 126.80 | 128.09 | 130.02 | 134.02 | 135.15 | 149.14 | 157.07 |
| Distances partielles TN |       | 24.02 | 16.50 | 7.09  | 7.18  | 22.62 | 3.41  | 23.19  | 19.72  | 3.06   | 1.30   | 1.93   | 3.99   | 1.14   | 13.98  | 7.94   |

Profil n°: M3

Echelle en X : 1/500

Echelle en Y : 1/200

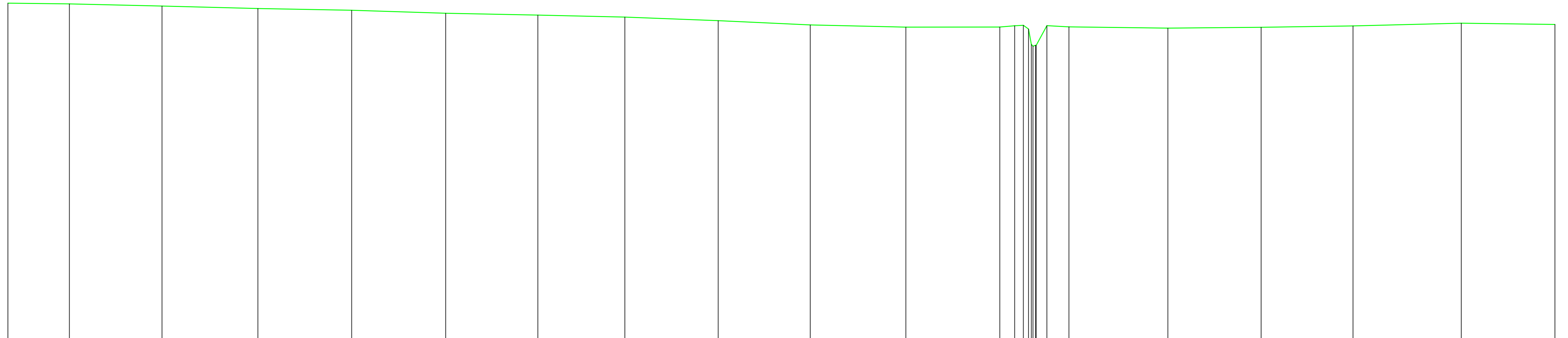

PC : 42.00 m

|                         |       |       |       |       |       |       |        |        |        |        |        |        |        |        |        |        |        |        |        |        |        |        |        |        |        |        |       |
|-------------------------|-------|-------|-------|-------|-------|-------|--------|--------|--------|--------|--------|--------|--------|--------|--------|--------|--------|--------|--------|--------|--------|--------|--------|--------|--------|--------|-------|
| Numéros des points TN   | 1     | 2     | 3     | 4     | 5     | 6     | 7      | 8      | 9      | 10     | 11     | 12     | 13     | 14     | 15     | 16     | 17     | 18     | 19     | 20     | 21     | 22     | 23     | 24     | 25     | 26     |       |
| Altitudes TN            | 69.06 | 69.00 | 68.83 | 68.63 | 68.49 | 68.25 | 68.10  | 67.94  | 67.85  | 67.81  | 67.73  | 67.71  | 67.14  | 67.24  | 67.26  | 67.28  | 67.29  | 67.27  | 67.25  | 67.15  | 67.15  | 67.05  | 67.12  | 67.12  | 67.23  | 67.45  | 67.35 |
| Distances cumulées TN   | 0.00  | 12.39 | 31.06 | 50.39 | 69.29 | 88.24 | 106.82 | 124.36 | 143.17 | 161.73 | 181.00 | 198.03 | 202.02 | 202.92 | 203.71 | 204.51 | 205.31 | 207.13 | 209.42 | 213.87 | 213.87 | 233.80 | 252.00 | 271.12 | 292.04 | 311.82 |       |
| Distances partielles TN |       | 12.39 | 18.67 | 19.33 | 18.90 | 18.95 | 18.58  | 17.54  | 18.81  | 18.56  | 19.27  | 18.93  | 3.00   | 1.70   | 1.03   | 1.42   | 2.28   | 4.45   | 19.93  | 18.80  | 18.52  | 21.82  | 18.88  |        |        |        |       |

Profil n°: M4

Echelle en X : 1/500

Echelle en Y : 1/200

PC : 40.00 m

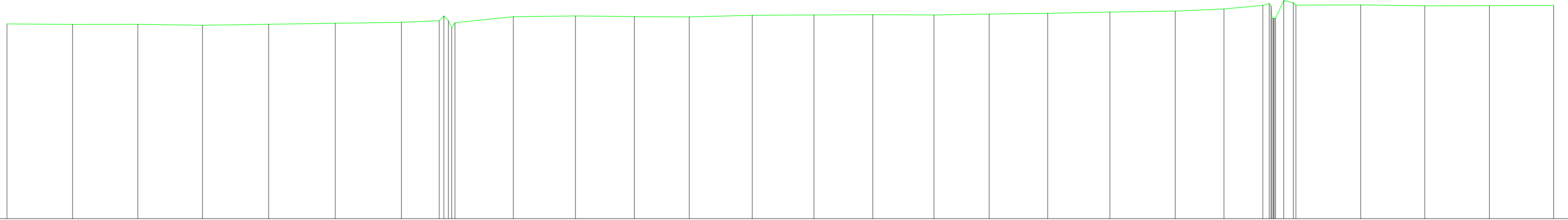

|                         |       |       |       |       |       |       |        |        |        |       |        |        |        |        |        |        |        |        |        |        |        |        |        |        |        |        |        |        |        |        |        |        |        |
|-------------------------|-------|-------|-------|-------|-------|-------|--------|--------|--------|-------|--------|--------|--------|--------|--------|--------|--------|--------|--------|--------|--------|--------|--------|--------|--------|--------|--------|--------|--------|--------|--------|--------|--------|
| Numéros des points TN   | 1     | 2     | 3     | 4     | 5     | 6     | 7      | 8      | 9      | 10    | 11     | 13     | 14     | 15     | 16     | 17     | 18     | 19     | 20     | 21     | 22     | 23     | 24     | 25     | 26     | 27     | 30     | 33     | 34     | 36     | 37     | 38     | 39     |
| Altitudes TN            | 63.46 | 63.40 | 63.41 | 63.30 | 63.42 | 63.54 | 63.65  | 63.85  | 64.42  | 64.42 | 63.00  | 64.33  | 64.42  | 64.34  | 64.31  | 64.50  | 64.54  | 64.57  | 64.54  | 64.65  | 64.74  | 64.89  | 65.01  | 65.26  | 65.70  | 65.62  | 64.19  | 65.28  | 66.01  | 65.75  | 65.64  | 65.66  | 65.70  |
| Distances cumulées TN   | 0.00  | 19.77 | 39.41 | 58.88 | 78.63 | 98.89 | 118.82 | 130.19 | 131.99 | 136   | 133.98 | 152.51 | 171.23 | 189.99 | 205.51 | 224.50 | 243.08 | 260.65 | 279.23 | 296.85 | 313.45 | 332.23 | 351.91 | 369.55 | 378.29 | 389.21 | 391.49 | 396.55 | 397.49 | 407.76 | 427.06 | 446.55 | 465.89 |
| Distances partielles TN |       | 19.77 | 19.65 | 19.47 | 19.95 | 20.06 | 19.93  | 11.37  | 1.40   | 1.36  | 1.30   | 18.55  | 18.72  | 17.76  | 16.52  | 18.98  | 18.58  | 17.72  | 18.43  | 16.62  | 17.63  | 18.74  | 19.68  | 14.68  | 11.71  | 1.82   | 1.21   | 3.09   | 2.91   | 20.27  | 19.30  | 19.49  | 19.34  |

Profil n°: M5

Echelle en X : 1/500

Echelle en Y : 1/200

PC : 39.00 m

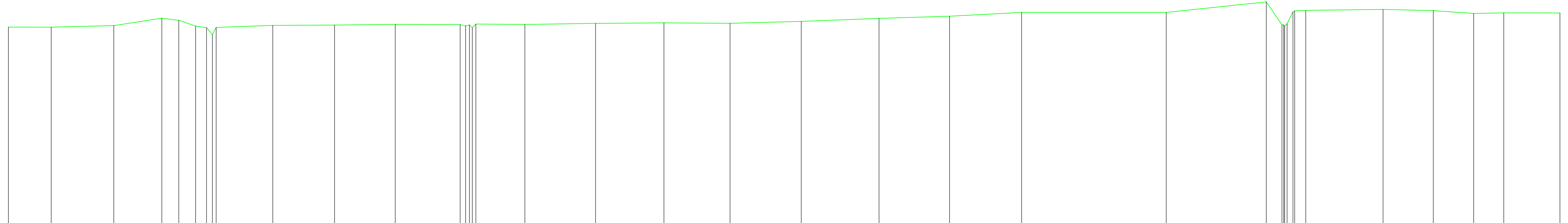

|                         |       |       |       |       |       |       |       |       |       |       |       |        |        |        |        |        |        |        |        |        |        |        |        |        |        |        |        |        |        |        |        |        |        |        |        |
|-------------------------|-------|-------|-------|-------|-------|-------|-------|-------|-------|-------|-------|--------|--------|--------|--------|--------|--------|--------|--------|--------|--------|--------|--------|--------|--------|--------|--------|--------|--------|--------|--------|--------|--------|--------|--------|
| Numéros des points TN   | 1     | 2     | 3     | 4     | 5     | 6     | 7     | 8     | 9     | 10    | 11    | 12     | 13     | 14     | 15     | 17     | 18     | 19     | 20     | 21     | 22     | 23     | 24     | 25     | 26     | 27     | 28     | 31     | 32     | 34     | 35     | 36     | 37     | 38     | 39     |
| Altitudes TN            | 62.85 | 62.84 | 62.82 | 62.71 | 62.68 | 62.77 | 62.58 | 61.75 | 62.60 | 62.85 | 62.88 | 62.97  | 62.94  | 62.79  | 62.71  | 62.54  | 62.98  | 63.08  | 63.15  | 63.09  | 63.33  | 63.69  | 63.95  | 64.41  | 64.41  | 66.07  | 62.82  | 63.05  | 64.49  | 64.65  | 64.77  | 64.62  | 64.29  | 64.35  | 64.34  |
| Distances cumulées TN   | 0.00  | 12.86 | 31.65 | 46.58 | 51.17 | 59.24 | 59.51 | 61.25 | 62.39 | 79.40 | 97.95 | 116.17 | 135.65 | 137.30 | 138.44 | 140.28 | 155.09 | 176.33 | 196.86 | 216.70 | 236.07 | 257.43 | 282.61 | 304.25 | 347.67 | 377.72 | 382.43 | 383.96 | 385.73 | 389.57 | 412.78 | 427.86 | 440.00 | 449.03 | 465.89 |
| Distances partielles TN |       | 12.86 | 18.79 | 14.43 | 5.09  | 5.06  | 3.27  | 1.74  | 1.14  | 17.00 | 18.55 | 18.22  | 19.48  | 1.65   | 1.14   | 1.84   | 14.72  | 21.23  | 20.53  | 19.84  | 21.37  | 23.36  | 21.18  | 21.64  | 43.42  | 30.05  | 4.71   | 1.53   | 1.76   | 3.84   | 23.21  | 15.08  | 12.14  | 9.03   | 16.86  |

Profil n°: M6

Echelle en X : 1/500

Echelle en Y : 1/200

PC : 38.00 m

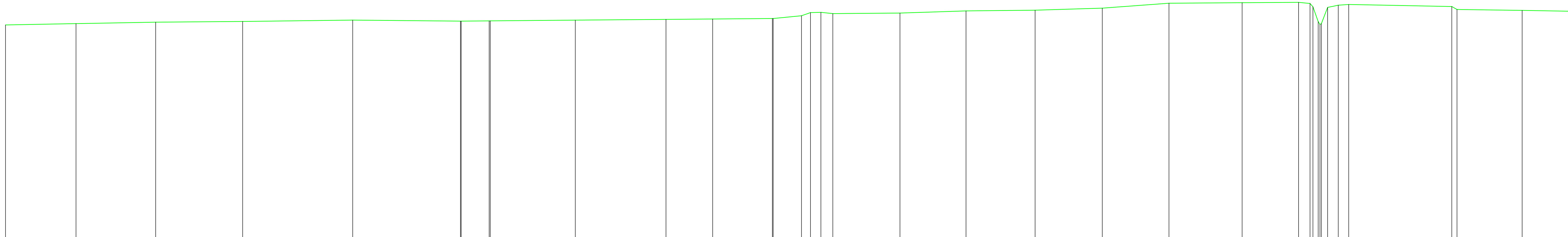

|                         |       |       |       |       |        |        |        |        |        |        |        |        |        |        |        |        |        |        |        |        |        |        |        |        |        |        |        |        |        |        |       |
|-------------------------|-------|-------|-------|-------|--------|--------|--------|--------|--------|--------|--------|--------|--------|--------|--------|--------|--------|--------|--------|--------|--------|--------|--------|--------|--------|--------|--------|--------|--------|--------|-------|
| Numéros des points TN   | 1     | 2     | 3     | 4     | 5      | 6      | 8      | 10     | 11     | 12     | 13     | 15     | 16     | 17     | 18     | 19     | 20     | 21     | 22     | 23     | 24     | 25     | 26     | 28     | 31     | 32     | 33     | 34     | 35     | 36     |       |
| Altitudes TN            | 61.80 | 61.95 | 62.11 | 62.19 | 62.34  | 62.23  | 62.25  | 62.34  | 62.42  | 62.46  | 62.52  | 62.83  | 63.18  | 63.21  | 63.07  | 63.13  | 63.37  | 63.45  | 63.88  | 64.23  | 64.29  | 64.33  | 64.30  | 62.18  | 63.76  | 64.01  | 64.09  | 63.86  | 63.53  | 63.43  |       |
| Distances cumulées TN   | 21.84 | 41.71 | 64.05 | 88.44 | 119.29 | 149.49 | 157.55 | 191.71 | 207.13 | 220.23 | 238.96 | 245.13 | 247.04 | 250.57 | 253.91 | 272.74 | 291.26 | 310.03 | 329.47 | 348.19 | 368.88 | 384.51 | 397.72 | 390.00 | 392.64 | 392.63 | 391.95 | 427.47 | 428.03 | 447.19 |       |
| Distances partielles TN |       | 19.78 | 22.34 | 24.39 | 30.86  | 30.20  | 8.06   | 24.15  | 25.42  | 13.10  | 16.73  | 8.17   | 2.52   | 2.93   | 3.34   | 18.83  | 18.52  | 19.37  | 18.84  | 18.69  | 20.51  | 15.83  | 3.21   | 2.28   | 2.64   | 2.99   | 2.93   | 28.90  | 1.48   | 18.26  | 18.70 |

Profil n°: M7

Echelle en X : 1/500

Echelle en Y : 1/200

PC : 37.00 m

|                         |       |       |        |        |        |        |        |        |        |        |        |        |        |        |        |        |        |        |        |        |        |        |        |        |        |        |        |        |        |        |        |        |        |        |       |
|-------------------------|-------|-------|--------|--------|--------|--------|--------|--------|--------|--------|--------|--------|--------|--------|--------|--------|--------|--------|--------|--------|--------|--------|--------|--------|--------|--------|--------|--------|--------|--------|--------|--------|--------|--------|-------|
| Numéros des points TN   | 1     | 2     | 3      | 5      | 7      | 8      | 9      | 10     | 12     | 13     | 14     | 15     | 16     | 18     | 19     | 20     | 22     | 23     | 24     | 26     | 27     | 28     | 29     | 30     | 31     | 32     | 33     | 34     | 35     | 36     | 38     | 39     | 40     | 41     | 42    |
| Altitudes TN            | 61.77 | 61.73 | 62.28  | 61.75  | 61.90  | 61.89  | 61.88  | 61.88  | 61.89  | 61.91  | 61.93  | 61.93  | 61.95  | 61.95  | 61.93  | 62.28  | 61.36  | 61.42  | 61.81  | 61.88  | 61.71  | 61.88  | 62.16  | 62.15  | 62.20  | 62.33  | 62.57  | 62.75  | 62.58  | 62.34  | 62.75  | 61.82  | 62.63  | 63.03  | 62.93 |
| Distances cumulées TN   | 68.04 | 96.04 | 101.96 | 106.14 | 118.07 | 119.94 | 148.17 | 152.12 | 156.33 | 172.24 | 188.12 | 192.03 | 202.99 | 205.17 | 224.10 | 256.63 | 244.12 | 246.71 | 248.88 | 252.95 | 255.32 | 270.10 | 282.80 | 315.97 | 330.34 | 355.14 | 374.46 | 380.89 | 387.26 | 389.76 | 401.77 | 403.21 | 407.96 | 410.04 |       |
| Distances partielles TN |       | 36.10 | 6.03   | 4.16   | 11.93  | 1.87   | 28.23  | 3.95   | 4.20   | 18.91  | 12.88  | 3.91   | 10.56  | 2.58   | 18.93  | 12.53  | 7.49   | 2.59   | 2.18   | 3.16   | 3.28   | 20.77  | 19.71  | 19.77  | 19.77  | 19.80  | 19.31  | 19.43  | 3.39   | 2.41   | 1.92   | 1.44   | 4.35   | 8.48   | 19.29 |



Profil n°: M8

Echelle en X : 1/500

Echelle en Y : 1/200

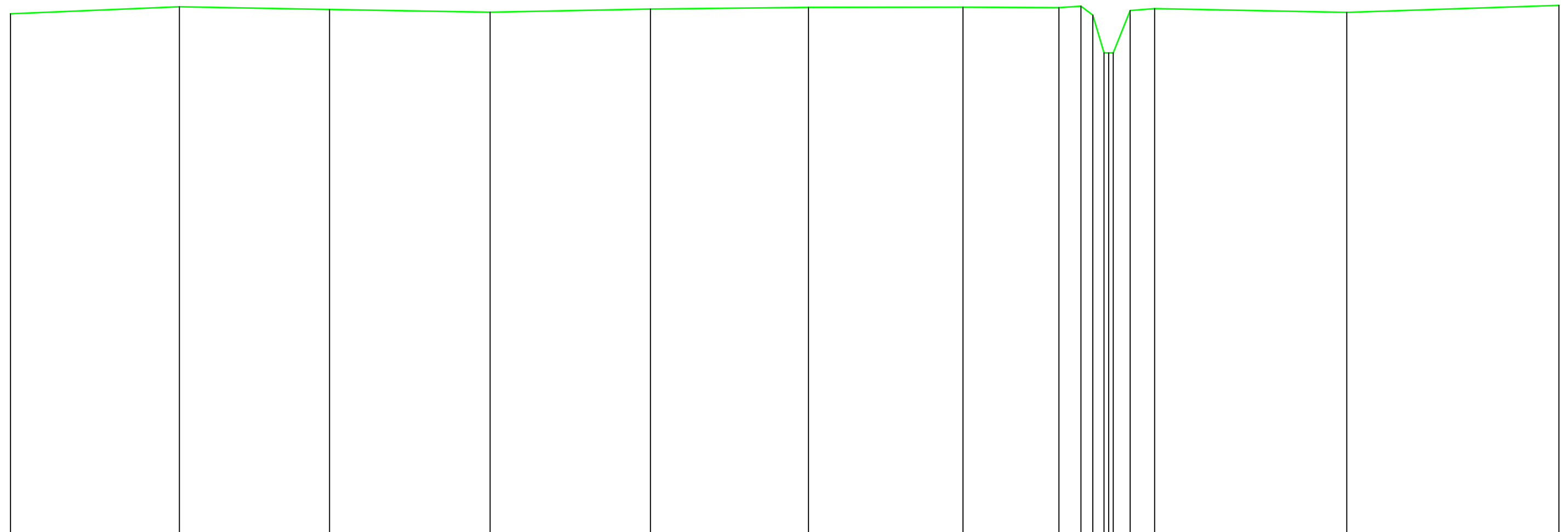

PC : 36.00 m

|                         |       |       |       |       |       |       |        |        |        |        |        |        |        |        |        |        |
|-------------------------|-------|-------|-------|-------|-------|-------|--------|--------|--------|--------|--------|--------|--------|--------|--------|--------|
| Numéros des points TN   | 1     | 2     | 3     | 4     | 5     | 6     | 7      | 8      | 9      | 10     | 11     | 13     | 14     | 15     | 16     | 17     |
| Altitudes TN            | 61.04 | 61.38 | 61.25 | 61.12 | 61.27 | 61.35 | 61.36  | 61.34  | 61.41  | 60.98  | 59.16  | 59.16  | 61.20  | 61.29  | 61.11  | 61.45  |
| Distances cumulées TN   | 0.00  | 20.38 | 38.50 | 57.67 | 77.22 | 96.29 | 114.94 | 126.52 | 129.17 | 130.60 | 131.95 | 133.06 | 135.11 | 138.06 | 161.24 | 166.95 |
| Distances partielles TN |       | 20.38 | 18.12 | 19.37 | 19.35 | 19.06 | 18.65  | 11.58  | 2.65   | 1.43   | 1.36   | 1.11   | 2.05   | 2.95   | 23.18  | 25.60  |

Profil n°: M9

Echelle en X : 1/500

Echelle en Y : 1/200

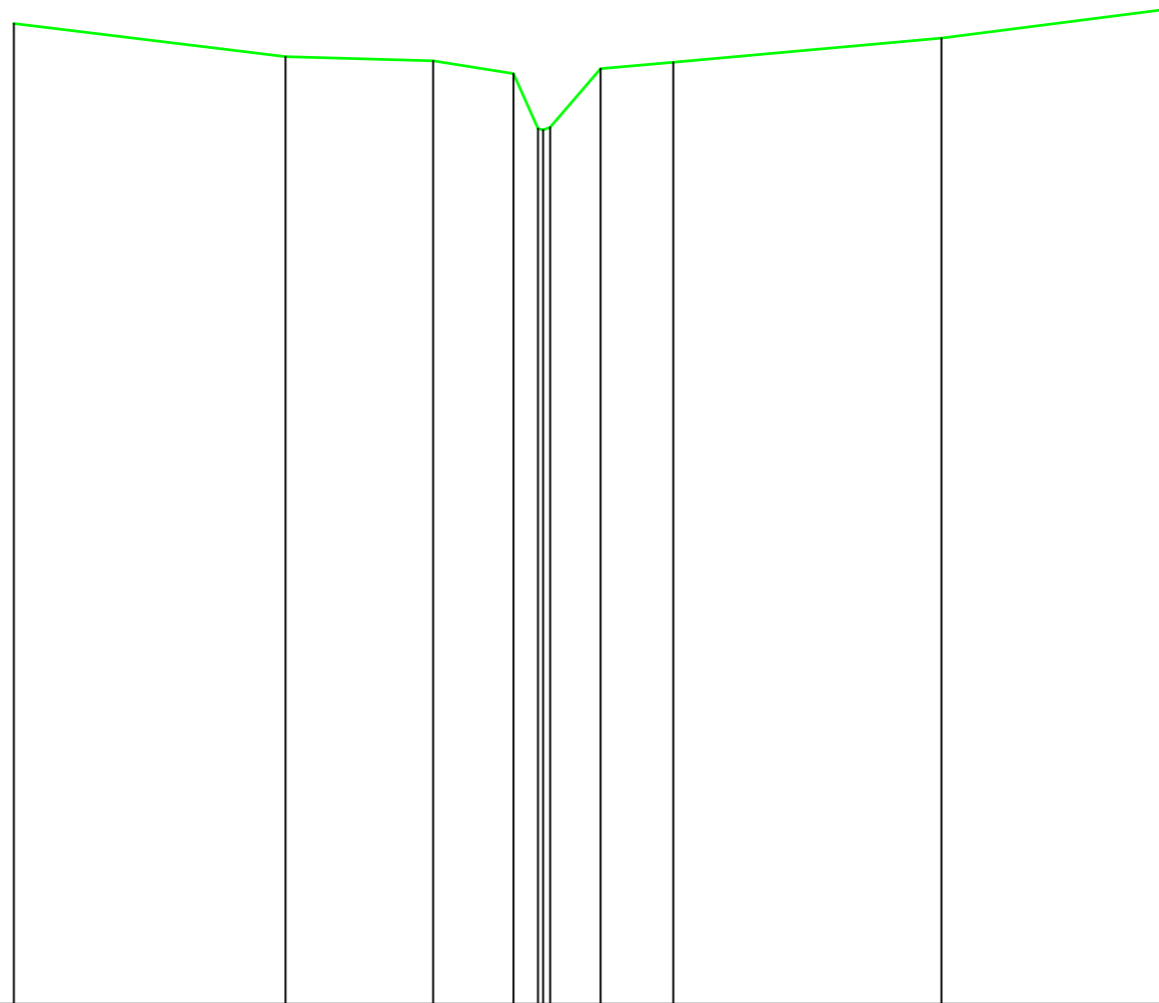

PC : 33.00 m

|                         |       |       |       |       |       |       |       |       |       |  |
|-------------------------|-------|-------|-------|-------|-------|-------|-------|-------|-------|--|
| Numéros des points TN   | 1     | 2     | 3     | 4     | 5     | 8     | 9     | 10    | 11    |  |
| Altitudes TN            | 56.93 | 56.05 | 57.94 | 57.60 | 56.15 | 57.73 | 57.90 | 56.54 | 56.32 |  |
| Distances cumulées TN   | 0.00  | 17.96 | 27.72 | 33.03 | 34.65 | 38.79 | 43.59 | 61.32 | 76.53 |  |
| Distances partielles TN |       | 17.96 | 9.76  | 5.31  | 1.62  | 4.13  | 4.80  | 17.73 | 15.21 |  |



# SYNDICAT MIXTE POUR LE DEVELOPPEMENT ECONOMIQUE DU NERACAIS

## Ruisseau de Malé



# RELEVÉ DES OUVRAGES

Date d'élaboration: Janvier 2016

Date d'édition: 22/02/2016

Modifié le :

Echelle 1/50

Réf dossier : 2016/0102

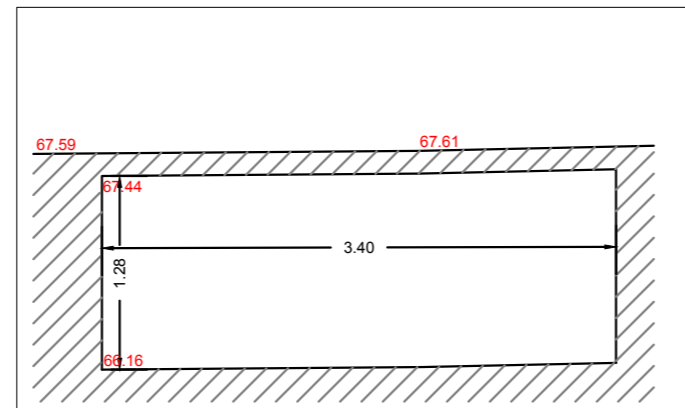

Ouvrage M1 AMONT

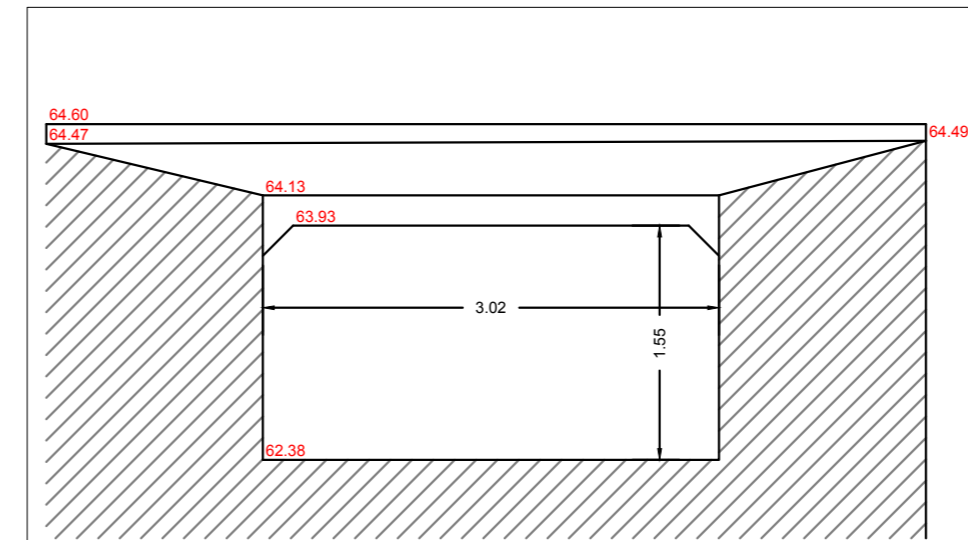

Ouvrage M2 AMONT

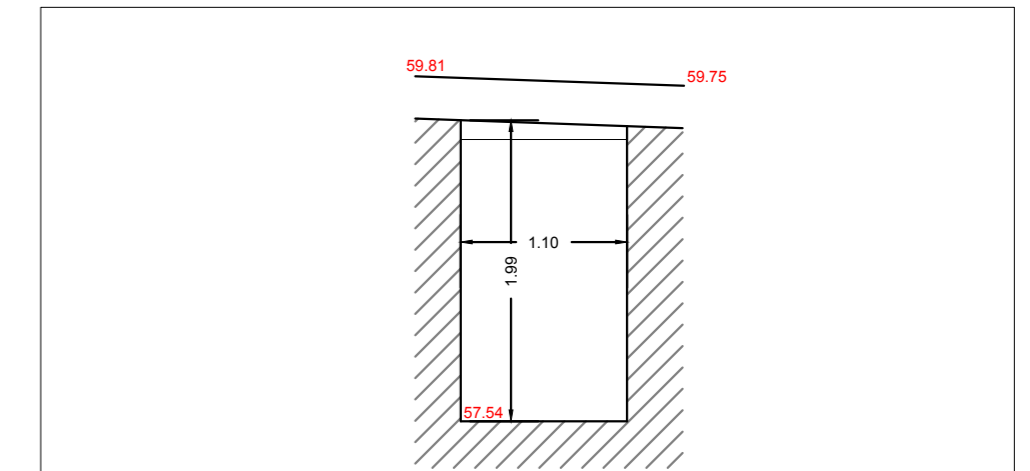

Ouvrage M3 AMONT

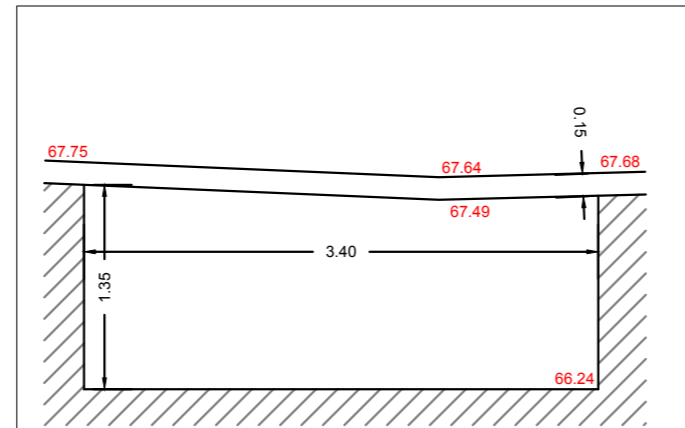

Ouvrage M1 AVA

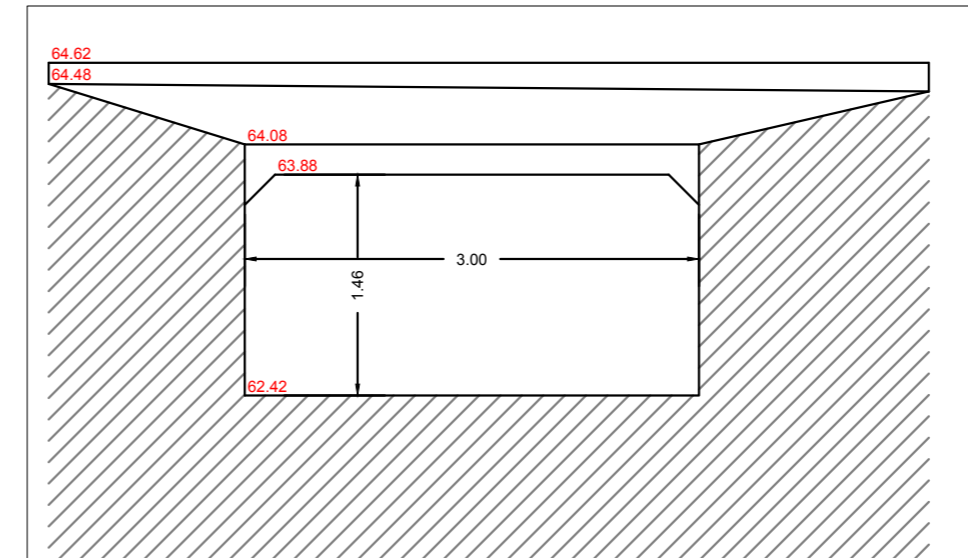

Ouvrage M2 AVA

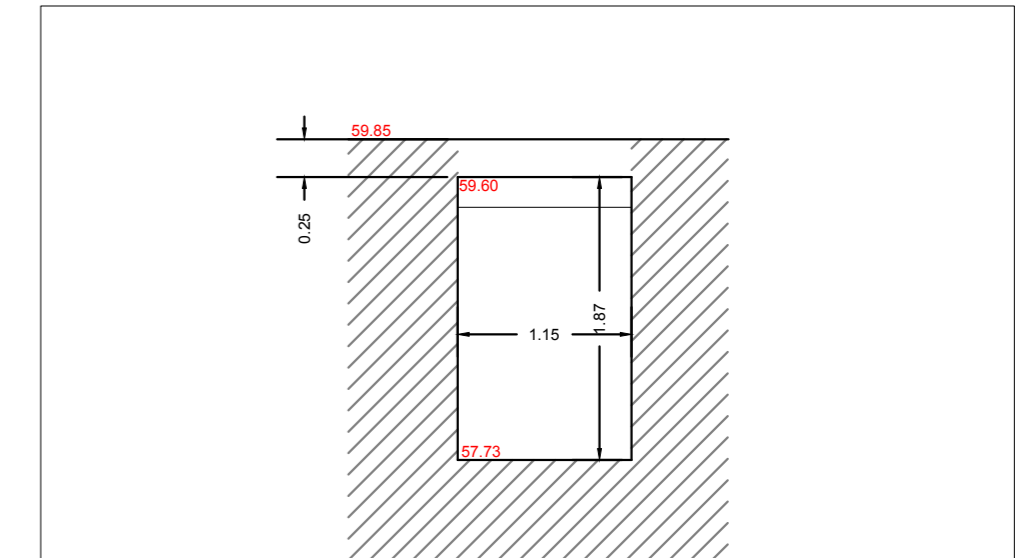

Ouvrage M3 AVA





# SYNDICAT MIXTE POUR LE DEVELOPPEMENT ECONOMIQUE DU NERACAIS

## Ruisseau de Caillou



# RELEVÉ ALTIMÉTRIQUES Profils C1 à C7

Date d'élaboration: Janvier 2016

Echelle 1/2000

Réf dossier : 2016/0102

Date d'édition: 22/02/2016

Modifié le :

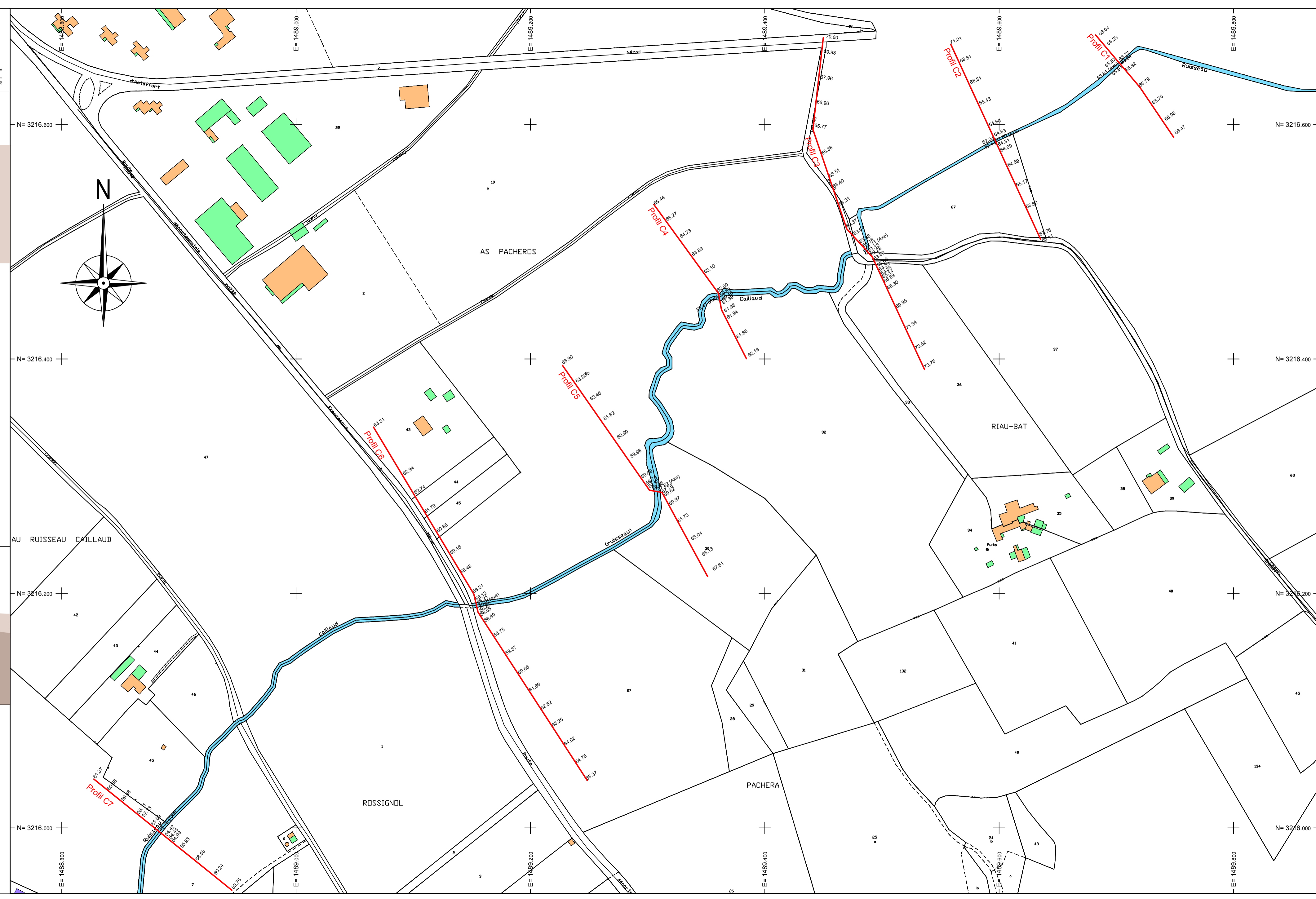



Profil n°: C1

Echelle en X : 1/500

Echelle en Y : 1/200

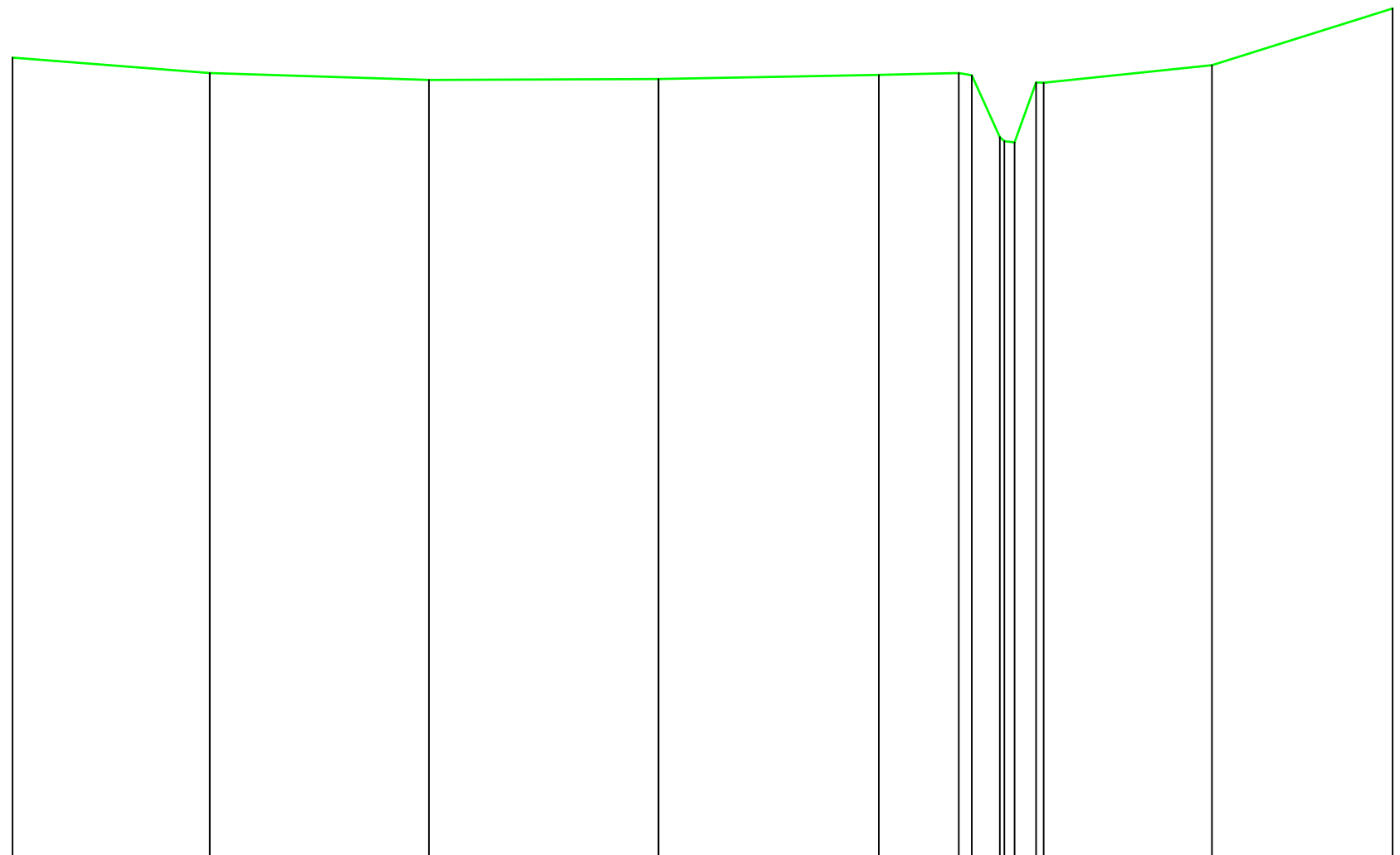

PC : 41.00 m

|                         |       |       |       |       |       |       |       |       |       |       |       |        |
|-------------------------|-------|-------|-------|-------|-------|-------|-------|-------|-------|-------|-------|--------|
| Numéros des points TN   | 1     | 2     | 3     | 4     | 5     | 6     | 7     | 8     | 10    | 11    | 13    | 14     |
| Altitudes TN            | 66.47 | 65.98 | 65.76 | 65.79 | 65.92 | 65.98 | 65.91 | 63.94 | 63.77 | 65.68 | 66.23 | 68.04  |
| Distances cumulées TN   | 0.00  | 15.72 | 33.18 | 51.47 | 69.02 | 75.40 | 76.44 | 78.67 | 79.84 | 81.56 | 95.57 | 109.96 |
| Distances partielles TN |       | 15.72 | 17.46 | 18.29 | 17.55 | 6.38  | 1.04  | 2.23  | 1.17  | 1.72  | 14.02 | 14.38  |

Profil n°: C2

Echelle en X : 1/500

Echelle en Y : 1/200

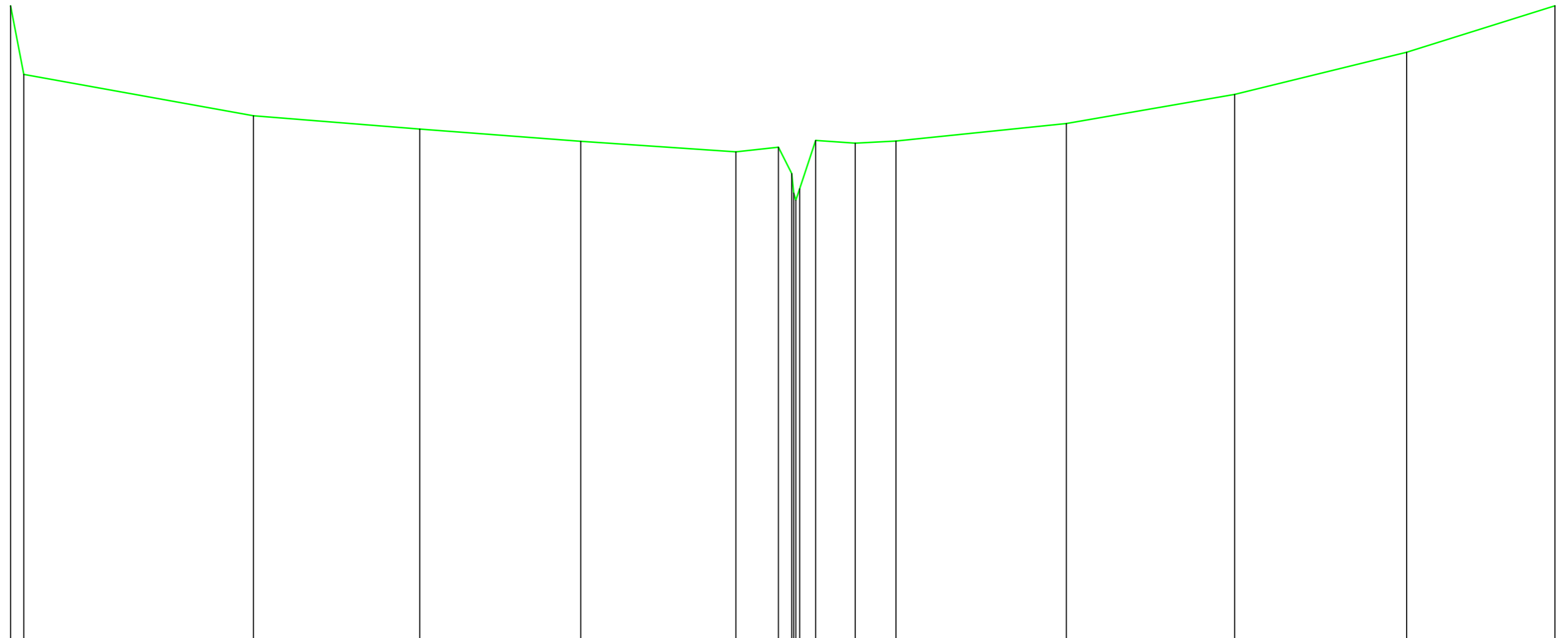

PC : 41.00 m

|                         |       |       |       |       |       |       |       |       |       |        |        |        |        |        |        |
|-------------------------|-------|-------|-------|-------|-------|-------|-------|-------|-------|--------|--------|--------|--------|--------|--------|
| Numéros des points TN   | 1     | 2     | 3     | 4     | 5     | 6     | 7     | 8     | 12    | 13     | 14     | 15     | 16     | 17     | 18     |
| Altitudes TN            | 71.01 | 67.76 | 65.80 | 65.17 | 64.59 | 64.09 | 64.31 | 63.06 | 64.63 | 64.50  | 64.60  | 66.43  | 66.81  | 66.81  | 71.01  |
| Distances cumulées TN   | 0.00  | 1.57  | 26.76 | 48.46 | 67.56 | 85.95 | 90.99 | 92.56 | 96.40 | 100.08 | 104.92 | 125.11 | 145.05 | 165.43 | 183.00 |
| Distances partielles TN |       | 1.57  | 27.21 | 19.70 | 19.08 | 18.38 | 5.04  | 1.57  | 2.84  | 4.69   | 4.83   | 20.19  | 19.94  | 20.38  | 17.57  |



Profil n°: C3

Echelle en X : 1/500

Echelle en Y : 1/200

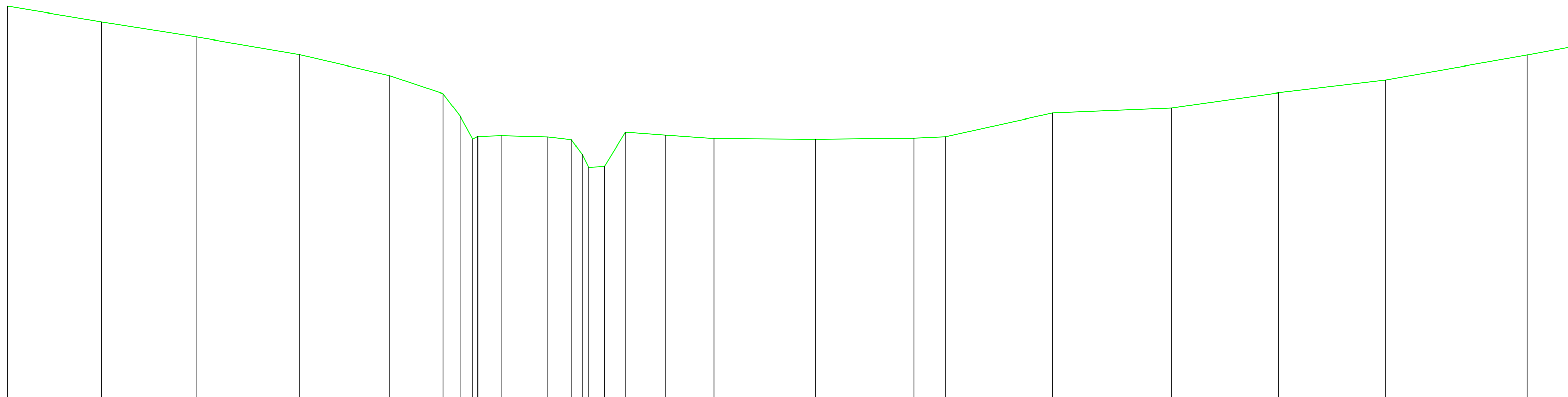

PC : 43.00 m

|                         |       |       |       |       |       |       |       |       |       |        |        |        |        |        |        |        |        |        |        |        |        |        |        |        |        |        |
|-------------------------|-------|-------|-------|-------|-------|-------|-------|-------|-------|--------|--------|--------|--------|--------|--------|--------|--------|--------|--------|--------|--------|--------|--------|--------|--------|--------|
| Numéros des points TN   | 1     | 2     | 3     | 4     | 5     | 6     | 7     | 8     | 10    | 11     | 12     | 13     | 14     | 15     | 16     | 17     | 18     | 19     | 20     | 21     | 22     | 23     | 24     | 25     | 26     | 27     |
| Altitudes TN            | 72.75 | 72.52 | 71.34 | 69.95 | 68.30 | 66.89 | 65.14 | 63.33 | 63.60 | 63.60  | 63.28  | 62.13  | 61.11  | 61.16  | 63.88  | 63.64  | 63.37  | 63.31  | 63.40  | 63.51  | 65.38  | 65.77  | 66.95  | 67.96  | 69.93  | 70.60  |
| Distances cumulées TN   | 0.00  | 18.37 | 36.89 | 57.16 | 74.76 | 85.20 | 88.52 | 91.02 | 96.60 | 107.72 | 110.31 | 114.43 | 113.70 | 116.76 | 120.91 | 128.77 | 132.23 | 152.09 | 177.26 | 183.47 | 204.46 | 227.75 | 248.69 | 269.61 | 297.35 | 306.42 |
| Distances partielles TN |       | 18.37 | 18.52 | 20.27 | 17.60 | 10.44 | 3.32  | 2.49  | 5.58  | 9.12   | 4.58   | 2.13   | 1.27   | 3.06   | 4.15   | 7.86   | 9.45   | 19.86  | 19.27  | 6.11   | 20.99  | 23.29  | 20.94  | 20.93  | 27.74  | 9.07   |

Profil n°: C4

Echelle en X : 1/500

Echelle en Y : 1/200

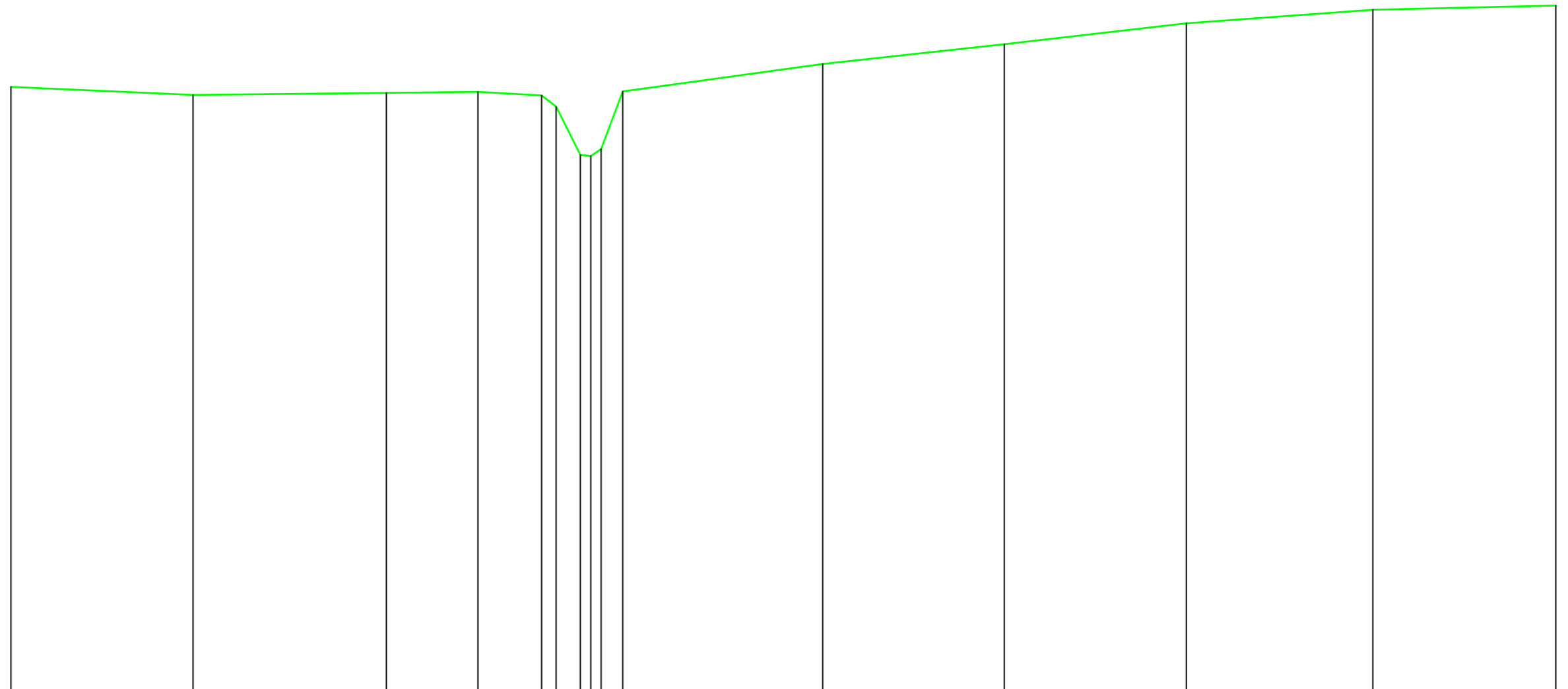

PC : 38.00 m

|                         |       |       |       |       |       |       |       |       |       |       |       |       |        |        |        |
|-------------------------|-------|-------|-------|-------|-------|-------|-------|-------|-------|-------|-------|-------|--------|--------|--------|
| Numéros des points TN   | 1     | 2     | 3     | 4     | 5     | 6     | 7     | 8     | 9     | 10    | 11    | 12    | 13     | 14     | 15     |
| Altitudes TN            | 62.18 | 61.98 | 61.94 | 61.98 | 61.84 | 61.39 | 59.48 | 59.41 | 59.69 | 62.00 | 63.10 | 63.89 | 64.73  | 65.27  | 65.44  |
| Distances cumulées TN   | 0.00  | 18.25 | 37.61 | 46.79 | 53.17 | 54.62 | 57.04 | 58.09 | 59.12 | 61.29 | 81.33 | 99.52 | 117.76 | 136.45 | 154.77 |
| Distances partielles TN |       | 18.25 | 19.36 | 9.18  | 6.38  | 1.45  | 2.42  | 1.05  | 1.03  | 2.17  | 20.04 | 18.19 | 18.24  | 18.68  | 18.33  |

Profil n°: C5

Echelle en X : 1/500

Echelle en Y : 1/200

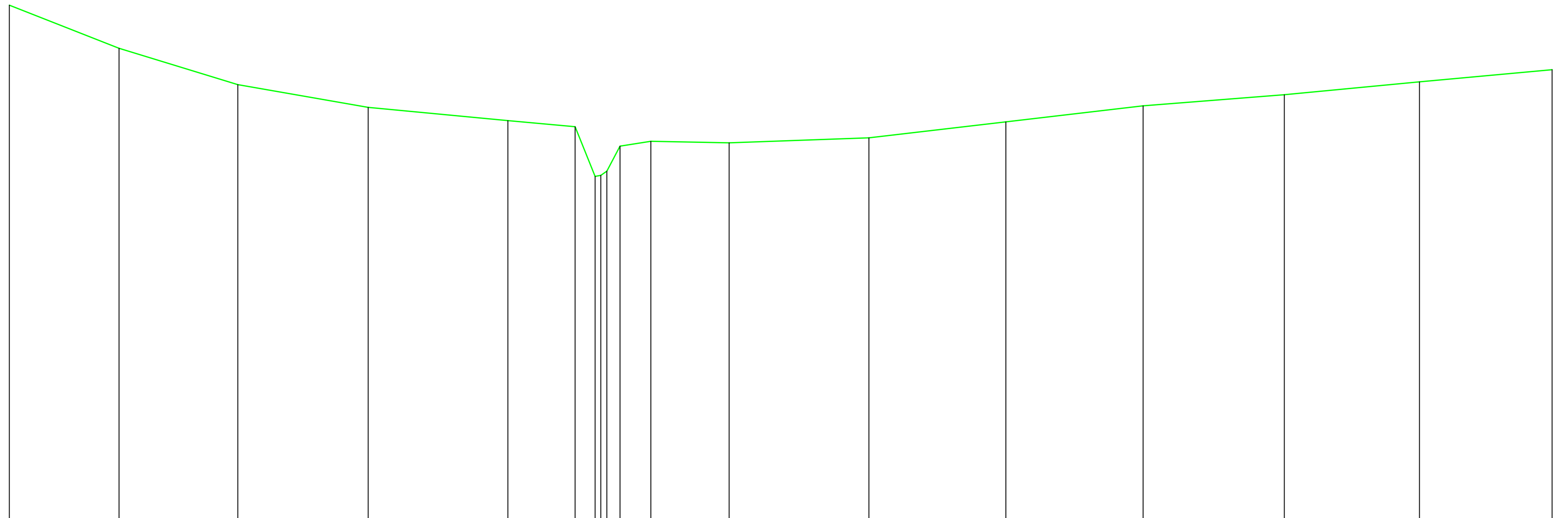

PC : 38.00 m

|                         |       |       |       |       |       |       |       |       |       |       |        |        |        |        |        |        |        |
|-------------------------|-------|-------|-------|-------|-------|-------|-------|-------|-------|-------|--------|--------|--------|--------|--------|--------|--------|
| Numéros des points TN   | 1     | 2     | 3     | 4     | 5     | 6     | 7     | 9     | 10    | 11    | 12     | 13     | 14     | 15     | 16     | 17     | 18     |
| Altitudes TN            | 67.61 | 65.13 | 63.04 | 61.73 | 60.97 | 60.62 | 67.76 | 58.06 | 59.50 | 59.78 | 59.69  | 59.98  | 60.90  | 61.82  | 62.46  | 63.20  | 63.90  |
| Distances cumulées TN   | 0.00  | 15.80 | 32.90 | 51.67 | 71.80 | 81.48 | 84.36 | 85.04 | 87.94 | 92.39 | 103.66 | 123.79 | 143.51 | 163.27 | 183.62 | 203.07 | 222.17 |
| Distances partielles TN |       | 15.80 | 17.10 | 18.78 | 20.12 | 9.68  | 2.88  | 1.68  | 1.90  | 4.45  | 11.27  | 20.13  | 19.72  | 19.76  | 20.35  | 19.45  | 19.10  |

Profil n°: C6

Echelle en X : 1/500

Echelle en Y : 1/200

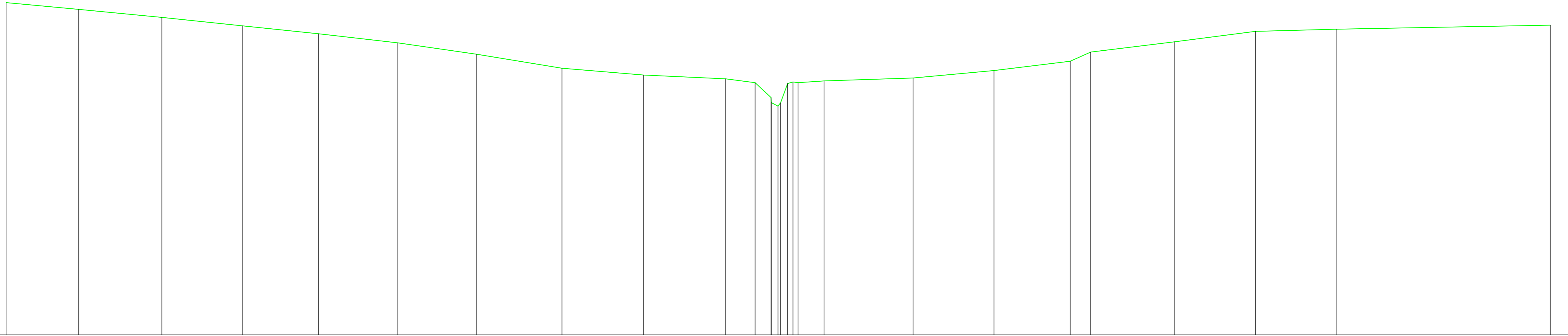

PC : 35.00 m

|                         |       |       |       |       |       |       |        |        |        |        |        |        |        |        |        |        |        |        |        |        |        |        |        |        |        |
|-------------------------|-------|-------|-------|-------|-------|-------|--------|--------|--------|--------|--------|--------|--------|--------|--------|--------|--------|--------|--------|--------|--------|--------|--------|--------|--------|
| Numéros des points TN   | 1     | 2     | 3     | 4     | 5     | 6     | 7      | 8      | 9      | 10     | 11     | 12     | 14     | 16     | 17     | 18     | 19     | 20     | 21     | 22     | 23     | 24     | 25     | 26     | 27     |
| Altitudes TN            | 66.37 | 64.75 | 64.02 | 63.25 | 62.32 | 61.69 | 60.95  | 60.37  | 59.75  | 59.40  | 59.05  | 58.09  | 58.91  | 57.97  | 58.12  | 58.05  | 58.21  | 58.48  | 58.16  | 60.01  | 60.95  | 61.79  | 62.74  | 62.94  | 63.31  |
| Distances cumulées TN   | 0.00  | 16.60 | 35.62 | 51.00 | 71.49 | 89.00 | 107.95 | 127.14 | 145.84 | 164.61 | 177.33 | 174.88 | 176.95 | 179.77 | 179.99 | 181.15 | 187.10 | 207.46 | 225.98 | 243.42 | 248.11 | 267.32 | 285.77 | 304.41 | 353.23 |
| Distances partielles TN |       | 16.60 | 19.01 | 18.39 | 17.49 | 18.11 | 18.06  | 19.49  | 18.70  | 18.76  | 6.73   | 3.65   | 1.58   | 2.22   | 1.21   | 1.12   | 5.95   | 20.36  | 18.51  | 17.44  | 4.69   | 19.22  | 18.45  | 18.64  | 48.82  |



Profil n°: C7

Echelle en X : 1/500

Echelle en Y : 1/200

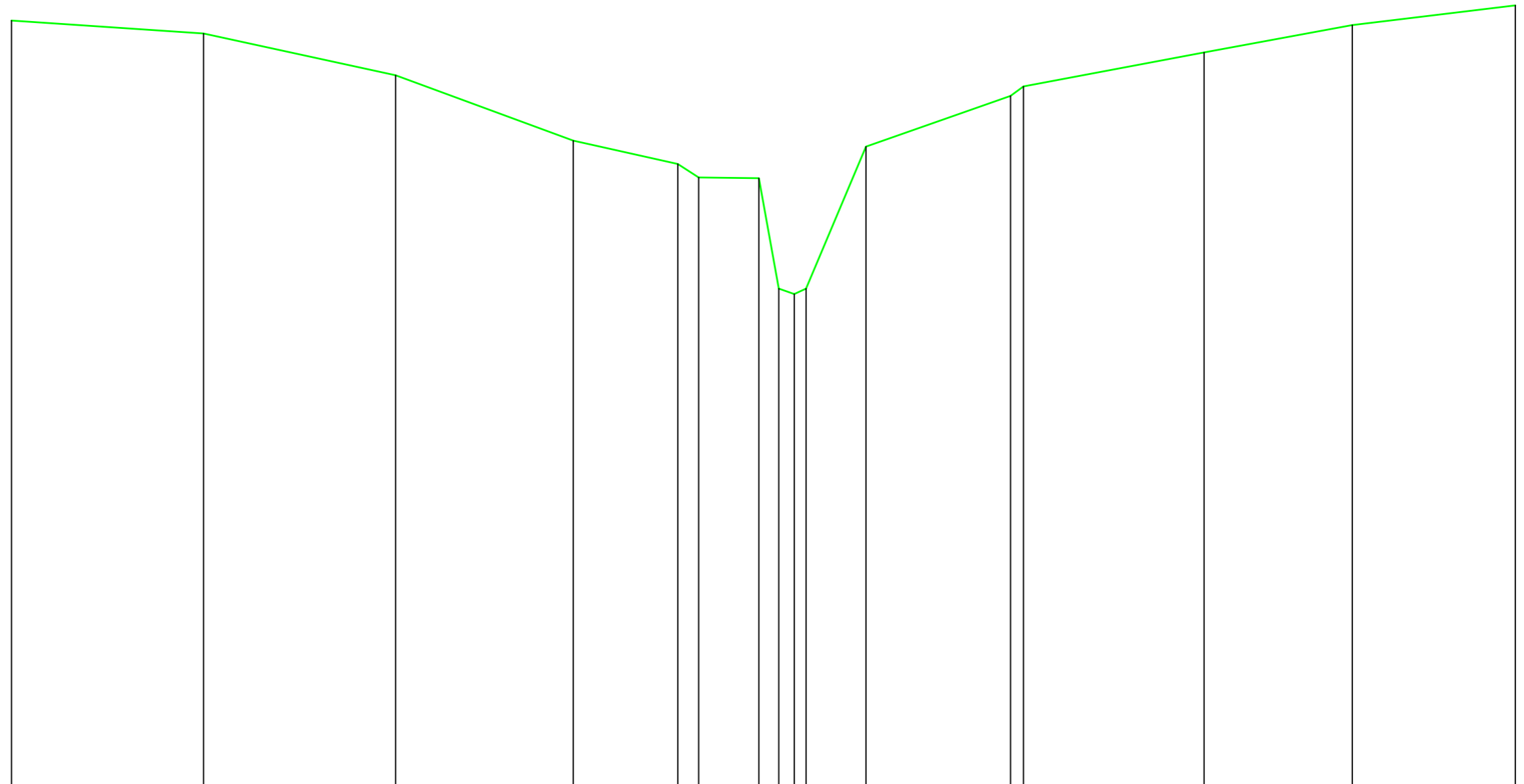

PC : 30.00 m

|                         |       |       |       |       |       |       |       |       |       |       |       |        |        |        |        |        |
|-------------------------|-------|-------|-------|-------|-------|-------|-------|-------|-------|-------|-------|--------|--------|--------|--------|--------|
| Numéros des points TN   | 1     | 2     | 3     | 4     | 5     | 6     | 7     | 8     | 9     | 10    | 11    | 12     | 13     | 14     | 15     | 16     |
| Altitudes TN            | 60.76 | 60.24 | 58.56 | 55.93 | 54.99 | 54.45 | 54.42 | 49.98 | 49.76 | 49.98 | 55.69 | 57.73  | 58.11  | 59.48  | 60.58  | 61.37  |
| Distances cumulées TN   | 0.00  | 19.30 | 38.61 | 55.46 | 66.97 | 69.06 | 75.12 | 77.12 | 78.67 | 79.86 | 85.88 | 100.41 | 101.71 | 119.86 | 134.76 | 151.15 |
| Distances partielles TN |       | 19.30 | 19.30 | 17.85 | 10.51 | 2.09  | 6.06  | 2.00  | 1.55  | 1.19  | 6.03  | 14.53  | 1.30   | 18.15  | 14.91  | 16.38  |



# SYNDICAT MIXTE POUR LE DEVELOPPEMENT ECONOMIQUE DU NERACAIS

## Ruisseau de Caillou



# RELEVÉ DES OUVRAGES

Date d'élaboration: Janvier 2016

Echelle 1/50

Réf dossier : 2016/0102

Date d'édition: 22/02/2016

Modifié le :

